

KEYS

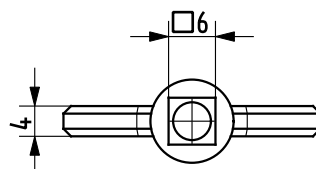

Note:
*available
with own logo
on request

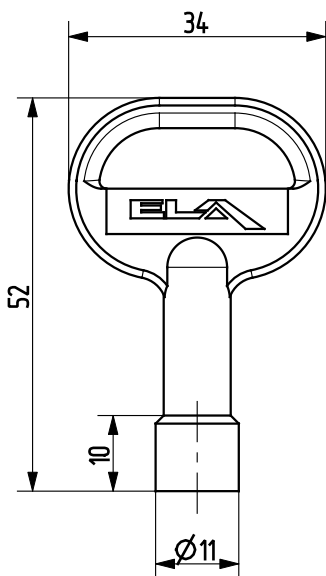

Part no.	Material	Surface
90ZA-ZK001-06*	zinc die	black powder coated

Note:
*available
with own logo
on request

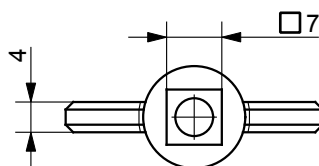
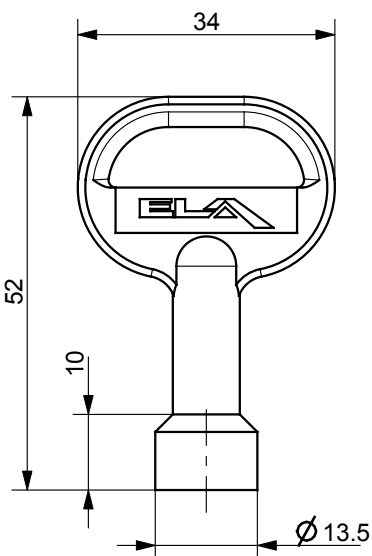

Part no.	Material	Surface	Version
90ZA-ZK002-06*	zinc die	black powder coated	□ 7 mm
90ZA-ZK003-06*	zinc die	black powder coated	□ 8 mm
90ZA-ZK004-06*	zinc die	black powder coated	△ 7 mm
90ZA-ZK005-06*	zinc die	black powder coated	△ 6.5 mm
90ZA-ZK006-06*	zinc die	black powder coated	△ 8 mm

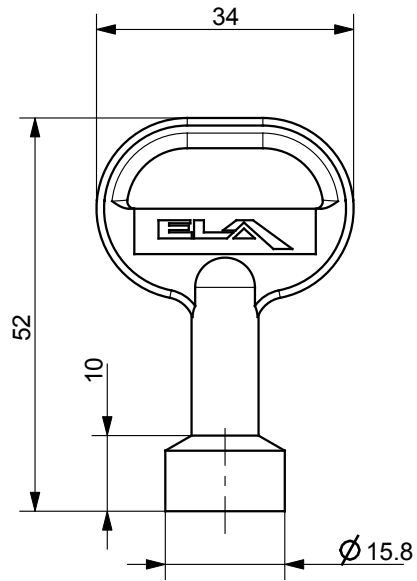
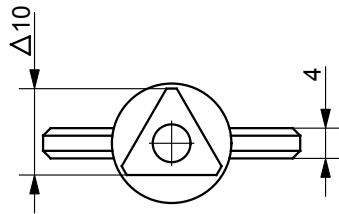

Note:
*available
with own logo
on request



Part no.	Material	Surface
90ZA-ZK007-06*	zinc die	black powder coated

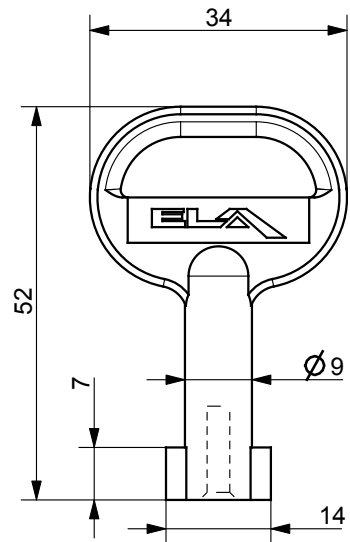
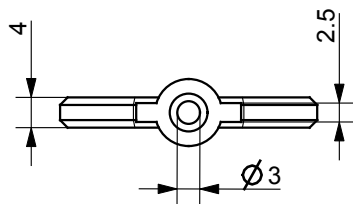

Note:
*available
with own logo
on request

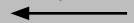

Part no.	Material	Surface	Version
90ZA-ZK008-06*	zinc die	black powder coated	3 mm double bit
90ZA-ZK009-06*	zinc die	zinc die	5 mm double bit

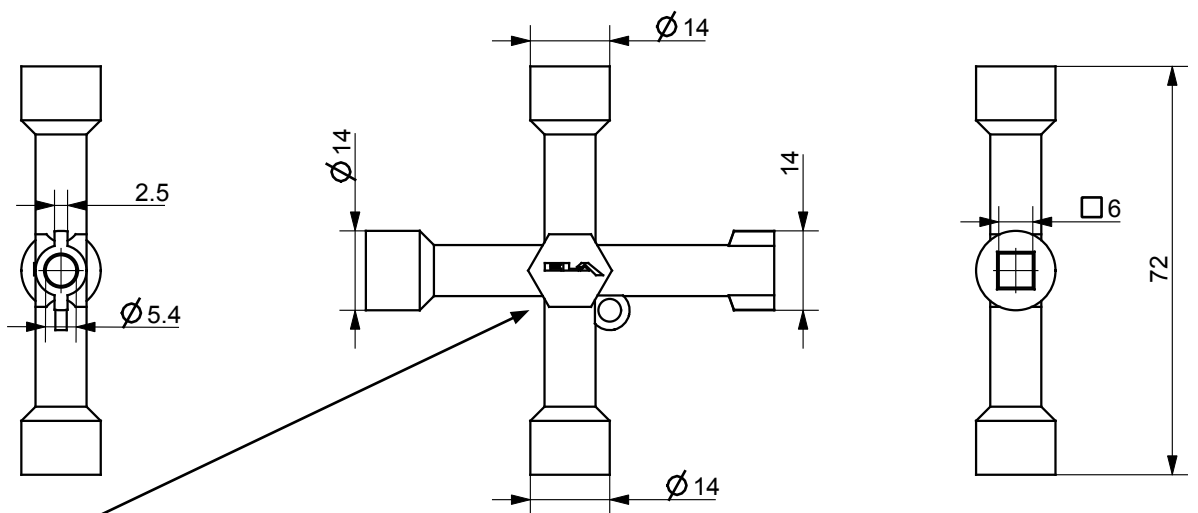
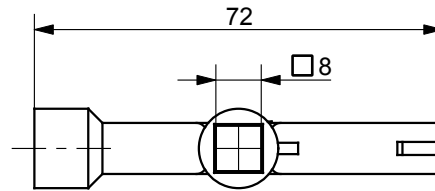

Note:
*available
with own logo
on request

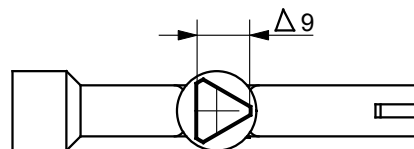

Part no.	Material	Surface
90ZA-ZK010-06*	zinc die	black powder coated

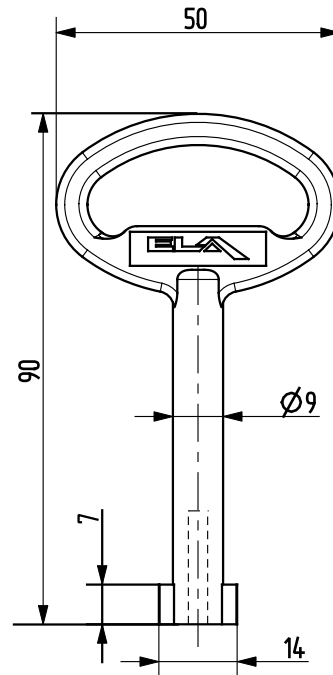
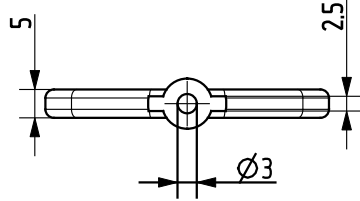

Note:
*available
with own logo
on request



Part no.	Material	Surface	Version
90ZA-ZK011-06*	zinc die	black powder coated	3 mm double bit
90ZA-ZK012-06*	zinc die	black powder coated	5 mm double bit

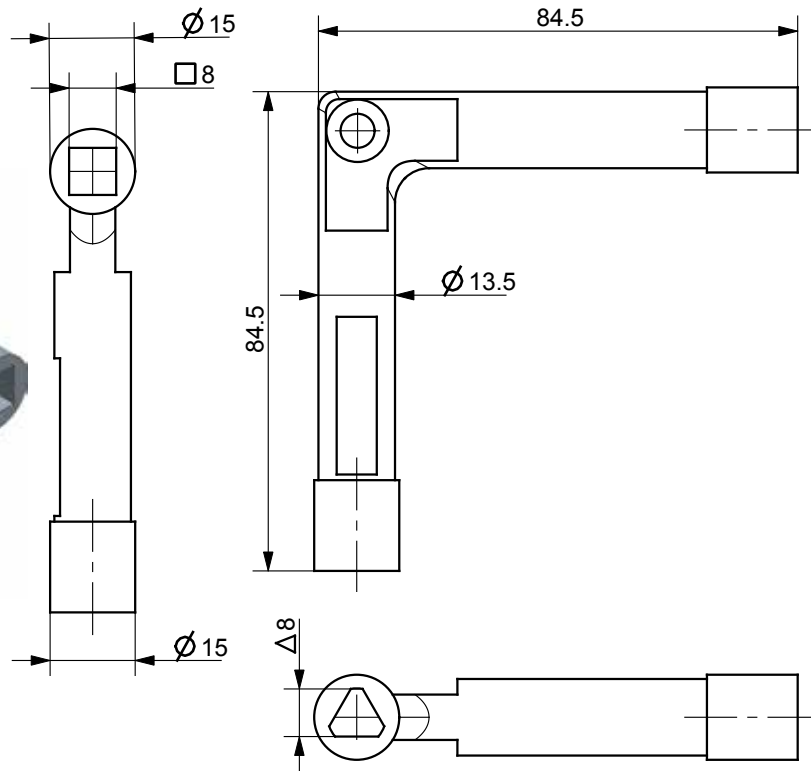

Part no.	Material	Surface
90ZA-ZK019-04	zinc die	chrome plated