

## HOUSINGS

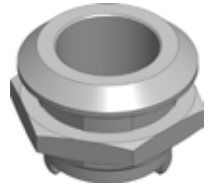

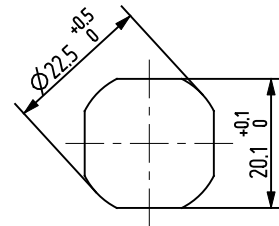
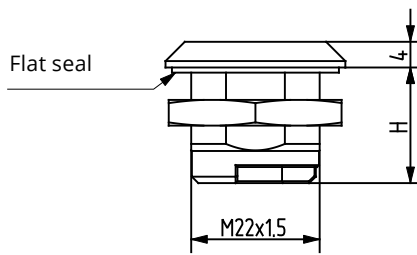
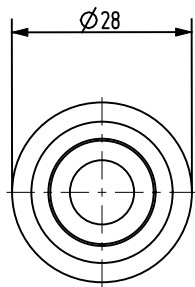

Cut out

Part no.	H (mm)	Material	Surface	Nut Material	Nut Surface
90KO-KH001-00	18	1.4305	-	1.4305	-
90KO-KH002-00	18	1.4571	-	1.4305	-
90KO-KH056-00	30	1.4305	-	1.4305	-
90KO-KH011-00	30	1.4571	-	1.4305	-
90KO-KH058-00	36	1.4305	-	1.4305	-
90KO-KH020-00	36	1.4571	-	1.4305	-
90KO-KH059-00	40	1.4305	-	1.4305	-
90KO-KH010-00	40	1.4571	-	1.4305	-
90KO-KH060-00	50	1.4305	-	1.4305	-
90KO-KH061-00	50	1.4571	-	1.4305	-
90KO-KH062-00	60	1.4305	-	1.4305	-
90KO-KH025-00	60	1.4571	-	1.4305	-

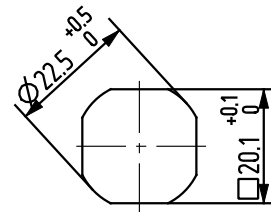
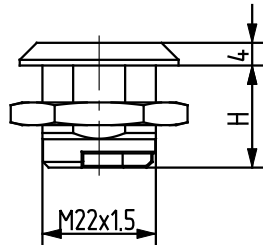
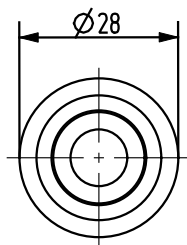

Cut out

**Note:**  
\*90PA-KH005-00  
with flat seal

Part no.	H (mm)	Material	Surface	Nut Material	Nut Surface
90PA-KH001-00	18	PA	-	ST	zinc plated
90PA-KH002-00	18	PA	-	zinc die	-
90PA-KH003-00	18	PA	-	PA	-
90PA-KH005-00*	18	PA	-	1.4305	-

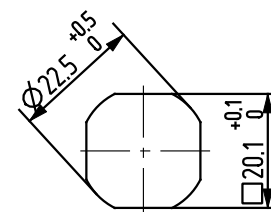
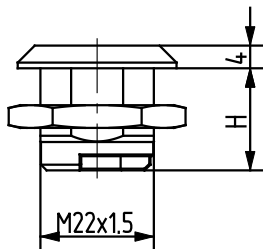
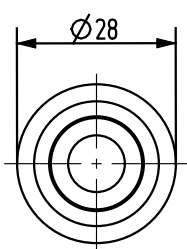

Cut out

**Note:**  
\*90ZA-KH005-04  
with earthnut

Part no.	H (mm)	Material	Surface	Nut Material	Nut Surface
90ZA-KH001-04	18	zinc die	chrome plated	zinc die	-
90ZA-KH005-04*	18	zinc die	chrome plated	zinc die	-

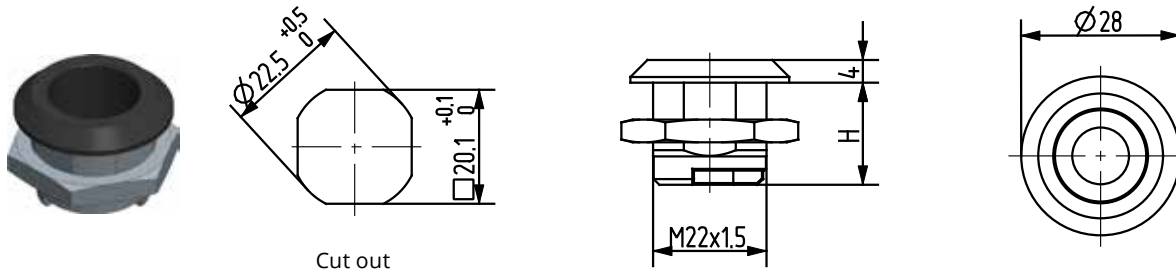

Cut out

Part no.	H (mm)	Material	Surface	Nut Material	Nut Surface
90ZA-KH001-06	18	zinc die	black powder coated	zinc die	-
90ZA-KH005-06*	18	zinc die	black powder coated	zinc die	-

**Note:**  
\*90ZA-KH005-06  
with earthnut

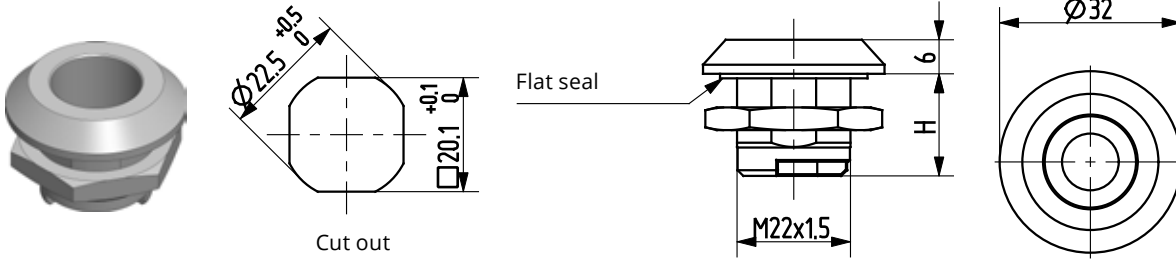

Cut out

Part no.	H (mm)	Material	Surface	Nut Material	Nut Surface
90KO-KH003-00	18	1.4305	-	1.4305	-
90KO-KH066-00	18	1.4571	-	1.4305	-
90KO-KH004-00	30	1.4305	-	1.4305	-
90KO-KH067-00	30	1.4571	-	1.4305	-
90KO-KH005-00	36	1.4305	-	1.4305	-
90KO-KH068-00	36	1.4571	-	1.4305	-
90KO-KH006-00	40	1.4305	-	1.4305	-
90KO-KH069-00	40	1.4571	-	1.4305	-
90KO-KH007-00	50	1.4305	-	1.4305	-
90KO-KH070-00	50	1.4571	-	1.4305	-
90KO-KH008-00	60	1.4305	-	1.4305	-
90KO-KH071-00	60	1.4571	-	1.4305	-

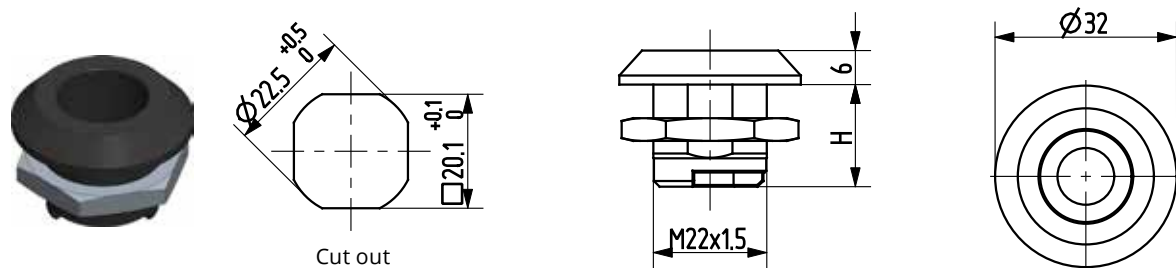

Cut out

Part no.	H (mm)	Material	Surface	Nut Material	Nut Surface
90PA-KH013-00	18	PA	-	zinc die	-
90PA-KH004-00	30	PA	-	zinc die	-
90PA-KH012-00	36	PA	-	zinc die	-
90PA-KH006-00	40	PA	-	zinc die	-
90PA-KH008-00	50	PA	-	zinc die	-
90PA-KH011-00	60	PA	-	zinc die	-

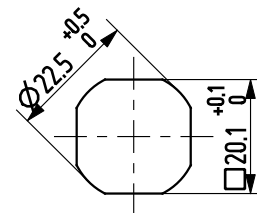
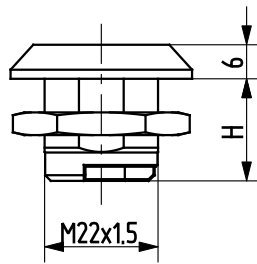
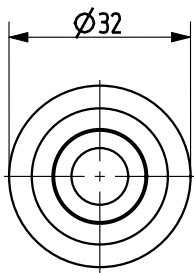

Cut out

Part no.	H (mm)	Material	Surface	Nut Material	Nut Surface
90ZA-KH003-04	18	zinc die	chrome plated	zinc die	-
90ZA-KH006-04	30	zinc die	chrome plated	zinc die	-
90ZA-KH012-04	36	zinc die	chrome plated	zinc die	-
90ZA-KH008-04	40	zinc die	chrome plated	zinc die	-
90ZA-KH009-04	50	zinc die	chrome plated	zinc die	-
90ZA-KH007-04	60	zinc die	chrome plated	zinc die	-

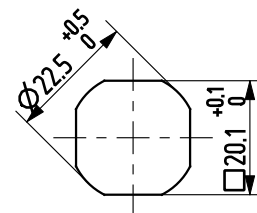
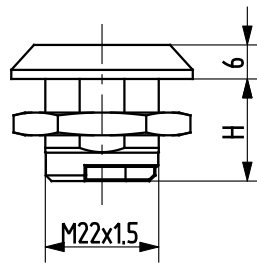
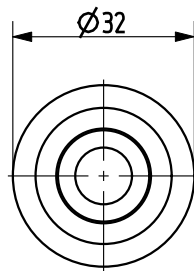

Cut out

Part no.	H (mm)	Material	Surface	Nut Material	Nut Surface
90ZA-KH003-06	18	zinc die	black powder coated	zinc die	-
90ZA-KH006-06	30	zinc die	black powder coated	zinc die	-
90ZA-KH012-06	36	zinc die	black powder coated	zinc die	-
90ZA-KH008-06	40	zinc die	black powder coated	zinc die	-
90ZA-KH009-06	50	zinc die	black powder coated	zinc die	-
90ZA-KH007-06	60	zinc die	black powder coated	zinc die	-

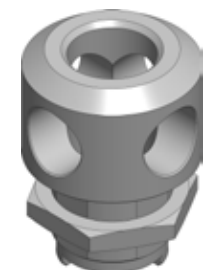
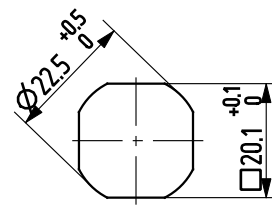
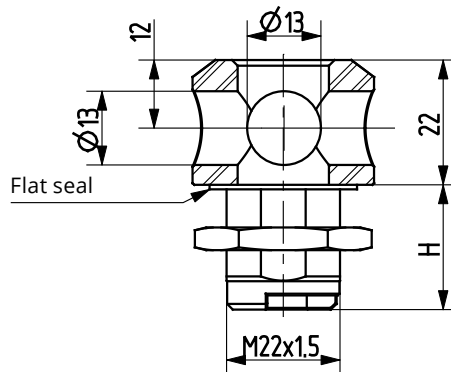
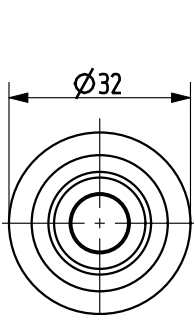

Cut out

Part no.	H (mm)	Material	Surface	Nut Material	Nut Surface
90KO-KH031-00	22	1.4305	-	1.4305	-
90KO-KH044-00	22	1.4571	-	1.4305	-

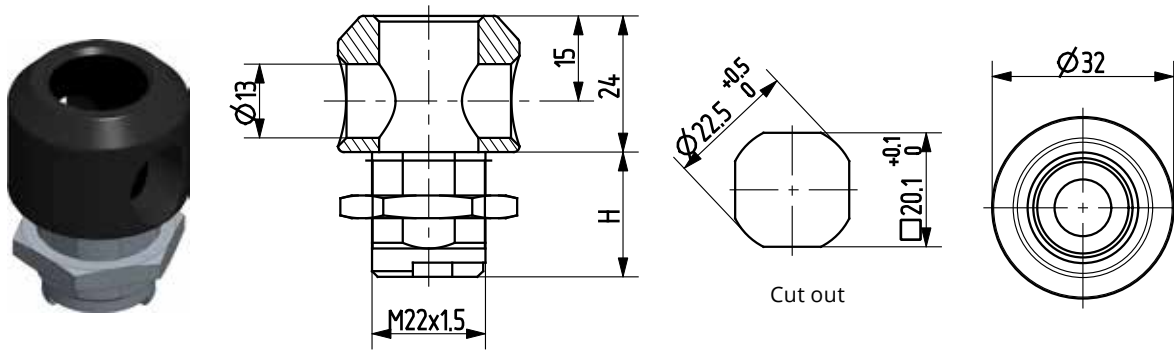

Part no.	H (mm)	Material	Surface	Nut Material	Nut Surface
90ZA-KH013-06	22	zinc die	black powder coated	zinc die	-
90ZA-KH014-06	32	zinc die	black powder coated	zinc die	-

### Railway

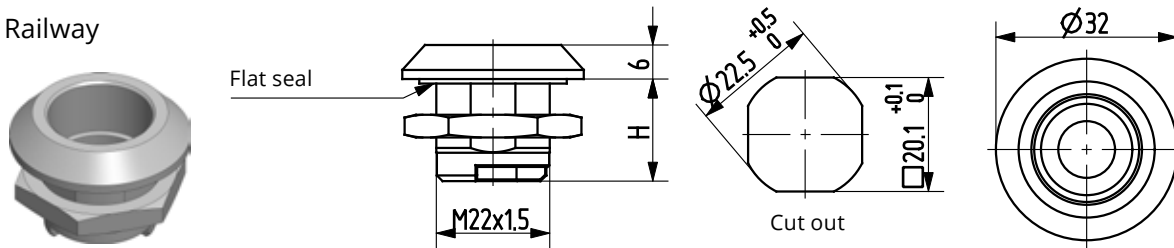

Part no.	H (mm)	Material	Surface	Nut Material	Nut Surface
90KO-KH017-00	18	1.4305	-	1.4305	-
90KO-KH045-00	18	1.4571	-	1.4305	-
90KO-KH046-00	30	1.4305	-	1.4305	-
90KO-KH047-00	30	1.4571	-	1.4305	-
90KO-KH048-00	36	1.4305	-	1.4305	-
90KO-KH049-00	36	1.4571	-	1.4305	-
90KO-KH050-00	40	1.4305	-	1.4305	-
90KO-KH051-00	40	1.4571	-	1.4305	-
90KO-KH052-00	50	1.4305	-	1.4305	-
90KO-KH053-00	50	1.4571	-	1.4305	-
90KO-KH054-00	60	1.4305	-	1.4305	-
90KO-KH055-00	60	1.4571	-	1.4305	-

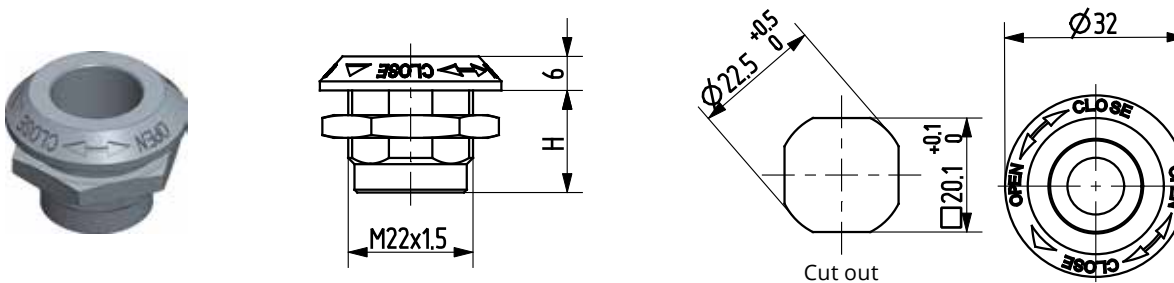

Part no.	H (mm)	Material	Surface	Nut Material	Nut Surface
90ZA-KH015-04	18	zinc die	chrome plated	zinc die	-
90ZA-KH016-04	30	zinc die	chrome plated	zinc die	-
90ZA-KH017-04	36	zinc die	chrome plated	zinc die	-
90ZA-KH018-04	40	zinc die	chrome plated	zinc die	-
90ZA-KH019-04	50	zinc die	chrome plated	zinc die	-
90ZA-KH020-04	60	zinc die	chrome plated	zinc die	-

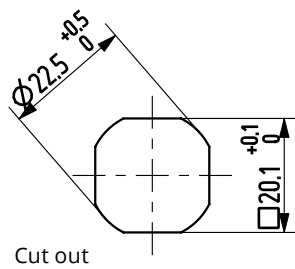
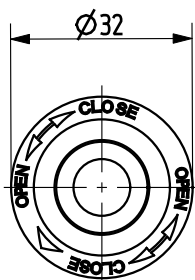

Cut out

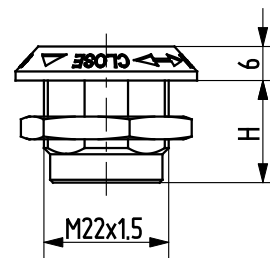

Part no.	H (mm)	Material	Surface	Nut Material	Nut Surface
90ZA-KH015-06	18	zinc die	chrome plated	zinc die	-
90ZA-KH016-06	30	zinc die	chrome plated	zinc die	-
90ZA-KH017-06	36	zinc die	chrome plated	zinc die	-
90ZA-KH018-06	40	zinc die	chrome plated	zinc die	-
90ZA-KH019-06	50	zinc die	chrome plated	zinc die	-
90ZA-KH020-06	60	zinc die	chrome plated	zinc die	-

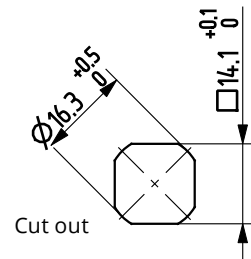
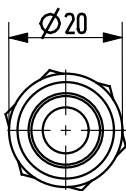

Cut out

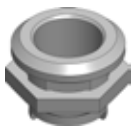
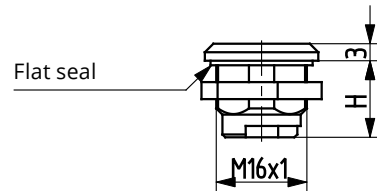

Part no.	H (mm)	Material	Surface	Nut Material	Nut Surface
90KO-KH021-00	13.5	1.4305	-	1.4305	-
90KO-KH040-00	13.5	1.4571	-	1.4305	-

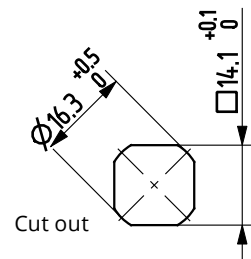
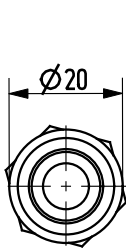

Cut out

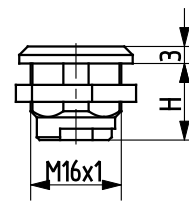

Part no.	H (mm)	Material	Surface	Nut Material	Nut Surface
90ZA-KH004-04	13.5	zinc die	chrome plated	zinc die	-

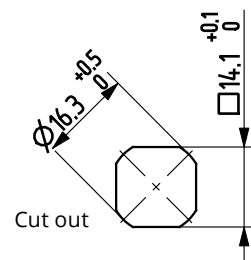
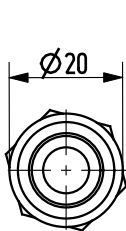

Cut out

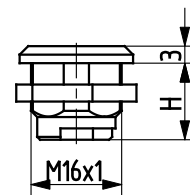

Part no.	H (mm)	Material	Surface	Nut Material	Nut Surface
90ZA-KH004-06	13.5	zinc die	black powder coated	zinc die	-